

**Saudi Electricity Company**



**الشركة السعودية للكهرباء**

**SEC DISTRIBUTION MATERIALS SPECIFICATION**

**31-SDMS-01, Rev. 02**

**DATE: 25-12-2006G**

**31-SDMS-01**

**REV. 02**

**SPECIFICATIONS**

**FOR**

**LOW VOLTAGE DISTRIBUTION PANEL**

**This specification is property of SEC and  
subject to change or modification without any notice**



## CONTENTS

<u>Clauses:</u>	<u>Page No.</u>
1.0 SCOPE .....	3
2.0 CROSS REFERENCES .....	3
3.0 APPLICABLE CODES AND STANDARDS .....	3
4.0 DESIGN AND CONSTRUCTION REQUIREMENTS .....	4
4.1 General .....	4
4.2 Incoming Transformer Connections .....	5
4.3 Busbars .....	5
4.4 Generator Connection .....	5
4.5 Neutral Busbar .....	6
4.6 Current Transformer .....	6
4.7 Ammeters .....	6
4.8 Voltmeters .....	6
4.9 KWH-Meter Wiring Provision .....	7
4.10 Outgoing MCCB's .....	7
Table-1 .....	8
4.11 Grounding .....	9
4.12 Internal Lighting .....	9
4.13 Auxiliary Supply .....	9
4.14 L.V. Cable Supports .....	9
4.15 Labels .....	10
4.16 Enclosure .....	10
4.17 Dimensions .....	11
5.0 NAME PLATE .....	11
6.0 MONOGRAMS & DANGER PLATES .....	12
7.0 TESTING .....	12
7.1 Type (Design) Test .....	12
7.2 Routine Test .....	12
8.0 INSPECTION .....	13
9.0 PACKING AND SHIPPING .....	13
10.0 GUARANTEE .....	13
11.0 SUBMITTALS .....	13
12.0 DATA SCHEDULE .....	15

### LIST OF FIGURES-DRAWINGS

<u>Figure No.</u>	<u>Description</u>	
3.	Wooden Cable Clamps .....	18
4.	Circuits Label .....	19
5.	Low Voltage Distribution Panel with door open .....	20
6.	Low Voltage Distribution Panel with door closed .....	21



## 1.0 SCOPE

This SEC Distribution Material Specification (SDMS) specifies the minimum technical requirements for design, materials, manufacturing, testing, inspection and performance for low voltage distribution panels, to be used in the distribution substations of the Saudi Electricity Company (SEC) in Saudi Arabia.

## 2.0 CROSS REFERENCES

This material standard specification shall be read in conjunction with the SEC specification No. 01-SDMS-01(latest revision), titled "General Requirements For All Equipment/Materials" which shall be considered as an integral part of this SDMS, also be read in conjunction with SEC purchase order (P.O.) requirements or contract schedules.

## 3.0 APPLICABLE CODES AND STANDARDS:

The latest revision of the following codes and standards shall be applicable for the equipment/materials covered in this specification. In case of any deviation, the vendor/manufacture may propose equipment/material conforming to an alternate code or standard without jeopardizing the requirements of this SDMS. However, the provision of SEC standard shall supersede the provision of these standards in case of any differences.

- 3.1 11-SDMS-01 1000V XLPE Insulated Unarmoured Power Cables.
- 3.2 37-SDMS-01 Low Voltage Moulded Case Circuit Breakers For Service Connections.
- 3.3 IEC 60529 Classification of Degree of Protection.
- 3.4 IEC 60185 Current Transformers.
- 3.5 IEC 60408 Low Voltage Air-Break Switches, Air-Break Disconnectors, Air-Break Switch-Disconnectors And Fuse-Combination Units.
- 3.6 IEC 60947 Low Voltage Switchgear And Control Gear.
- 3.7 IEC 60114 Indicating Instruments.
- 3.8 IEC 60439-1 Temperature Rise For Low Voltage Panel.
- 3.9 ASTM B103 Phosphor Bronze Plate, Sheets, Strip & Rolled Bar.



- 3.10 ASTM D1535 Paints, Color.
- 3.11 ASTM B117 Coating
- 3.12 ASTM D1654 Salt Spray Test.
- 3.13 ASTM D3359 Tape (Scratch) Test.
- 3.14 ASTM A153 Zinc Coating (hot-dip) On Iron And Steel Hardware.

#### **4.0 DESIGN AND CONSTRUCTION REQUIREMENTS**

##### **4.1 General**

- 4.1.1 The panel shall be supplied with an enclosure which contains incoming transformer connections, busbars, instruments panel, 400A molded case circuit breakers (MCCB) for out-going circuits, neutral busbar, earthing terminals, and the provision for generator connections.
- 4.1.2 All cable terminations shall easily be accessible from the front.
- 4.1.3 All insulating materials shall be non-hygroscopic and resistant to tracking and cracking.
- 4.1.4 Panel completes with all its fittings and attachments shall be capable of withstanding the effects of direct solar radiation at their installed locations. The temperature of metal surfaces exposed to direct solar radiation shall be regarded as 75° C, plus the effect of any internal heating.
- 4.1.5 Thermal inter-action shall not unduly affect the performance of any components.
- 4.1.6 All parts of equal size and shape shall be interchangeable. The general design shall be made with minimum number of joints.
- 4.1.7 All connections inside the panel shall have minimum clearance which shall not be less than 25.4 mm between phase and ground as per NEMA standard. In case the above clearance cannot be obtained, adequate insulating material shall be provided.  
All bolts & nuts shall be installed in a way that they could not be unbolted from outside the panel. Extra length of fasteners shall be avoided.



#### 4.2 **Incoming Transformer Connections:**

- 4.2.1 For unit and package substations, incoming transformer connections shall be through L.V. busbars. Removable copper links shall be provided to enable disconnection of incoming transformer busbar connection from L.V. busbar.
- 4.2.2 Stand-alone L.V. Panel shall permit the use of single core copper cable of size 630mm<sup>2</sup> with compression lugs as shown in Figure (2) of spec No 12-SDMS-02. These lugs will be supplied by SEC. M10x70mm bolts with nuts and washers shall be provided. Number of incoming cables shall be as specified in Table-1 of this specification.

#### 4.3 **Busbars:**

- 4.3.1 The Busbars shall be hard drawn high conductivity tinned copper of uniform cross section as per UNS No. C53400 of ASTM B103 or approved equivalent.
- 4.3.2 The cross sectional area of busbars shall be as per Table-1 of this specification.
- 4.3.3 All bolted electrical joints shall be secured by corrosion proof steel fasteners. All bolts, nuts, washers and studs shall be galvanized and comply with SEC specification 01-SDMS-01.
- 4.3.4 Adequate insulating barrier between the operator and the live busbars shall be provided.
- 4.3.5 Phase busbars shall be color marked in sequence from top to bottom red, yellow, blue and neutral busbar shall be marked black. The marking shall be by indelible paint at the ends and the middle of the busbars.
- 4.3.6 Busbars shall be spaced and staggered in such a way that installation of MCCBs and associated cables can be achieved without any difficulty using common tool.
- 4.3.7 Phase busbars shall have the provision to accommodate CT's with internal dimensions of 30x100mm for partial metering of L.V. panel.

#### 4.4 **Generator Connection:**

Holes of 13mm diameter for installation of mobile generator shall be provided. The distance between each two holes shall be 50mm center to center, the holes shall be



suitable for NEMA type lugs to be provided by SEC. Holes shall be (2) two for L.V. panel up to 1600A rating and (4) four for L.V. panel exceeding 1600A.

#### 4.5 **Neutral Busbar:**

The size of neutral busbar shall be as per Table-1 of this specification. It shall be insulated from the frame of the distribution panel, but connected to the frame by a bolted easily removable link. Holes of 13mm diameter shall be provided for each outgoing cable connection (lug type).

#### 4.6 **Current Transformer:**

Three Current Transformers conforming to IEC-60185 shall be installed at the incoming busbars of the distribution panel for metering purpose, CT secondary neutral point shall be earthed. The current rating is indicated in Table-1 of this specification.

CTs shall have the following characteristics:

Accuracy Class:	0.5
Rated Burden:	10 VA
Error Co-efficient:	Less than 5
Insulation Class:	Class-E, 120°C

#### 4.7 **Ammeters:**

Three flush mounting Ammeters shall be provided on the distribution panel. These shall have the following characteristics:

4.7.1 Bi-metal instruments with instantaneous reading and integrated 15 minutes maximum demand indicator.

4.7.2 Ammeters scale as indicated in Table-1 of this specification.

4.7.3 Size of scale shall be 96mm x 96mm according to DIN-43700 or other equivalent standard.

#### 4.8 **Voltmeters:**

Voltmeter with phase to phase and phase to neutral selector switch for seven position shall be provided as follows:



4.8.1 Voltmeter scale shall be:

0-500 Volts for 400 Volts Secondary line voltage.

0-300 Volts for 231 Volts Secondary line voltage.

4.8.2 Size of scale shall be 96 mm x 96 mm according to DIN-43700 or other equivalent standard.

4.9 **KWH-Meter Wiring Provision:**

All wiring shall be 2.5 mm<sup>2</sup> copper conductor black PVC. Connectors shall be full ring insulated crimp type. CT short circuit links shall be provided on terminal block. KWH-Meter wiring shall be made direct without Fuses. Duly wired terminal block for connection of a 3-phase 4-wire CT KWH-Meter shall be provided in L.V. Panel.

4.10 **Outgoing MCCB's:**

4.10.1 Provision for installation of 400A MCCB's shall be made available for each outgoing feeder and suitable for installing at least 3 SEC approved MCCB's. Unless otherwise specified in the tender, number of MCCB's supplied/installed in the L.V. Panel shall be 50% of the no. of outgoing MCCB's in Table-1.

4.10.2 400A MCCB shall comply with SEC spec. 37-SDMS-01. Terminals shall be suitable for direct connection of 300mm<sup>2</sup> Al. cable as per SEC spec. 11-SDMS-01 by means of bimetallic lugs with M10 bolt and palm width of 30mm. as per fig # 5 of spec 12-SDMS-02

4.10.3 These MCCB's shall comply the following:

- (A) Easily interchangeable with at least 3 SEC approved manufacturers, if possible.
- (B) Without lock and without terminal spreaders.
- (C) With current limiting functions.



**Table (1)**  
**Low Voltage Distribution Panel**

Components	TRANSFORMER RATING							
	300kVA		500kVA		1000kVA		1500kVA	
	231/133 V	400/231 V	231/133 V (I)	400/231 V	231/133 V (II)	400/231 V	231/133 V (III)	400/231 V
L.V. Panel incoming busbar/link rating (A) minimum	800	500	1600	800	3000	1600	4000	2500
CT rating on incoming busbars (A)	750/5	750/5	1500/5	750/5	3000/5	1500/5	4000/5	3000/5
Incoming cables for standalone L.V panel	2/ph 1/N	2/ph 1/N	2/ph 1/N	2/ph 1/N	4/ph 2/N	2/ph 1/N	6/ph 3/N	4/ph 2/N
For L.V. panel used in unit/package substations	Incoming connection shall be through copper busbar links from back of the panel							
Number of Outgoing MCCB's	4	2	8	4	12	8	14	10
Minimum Spacing MCCB's	Not less than 10mm							
Phase Busbars min. cross section (mm <sup>2</sup> )	10x50	10x50	10x100	10x50	2x10x100	10x100	3x10x100	2x10x100
Phase Busbars min. Rating, (A)	800	500	1600	800	3000	1600	4000	2500
Neutral Busbar min. Size (mm <sup>2</sup> )	5x50	5x50	10x50	5x50	10x100	10x50	2x10x100	10x100
Neutral Busbar min. Rating, (A)	400	250	800	400	1600	1000	2500	1600
Ammeter Scale	0-750	0-750	0-1800	0-750	0-3000	0-1800	0-4000	0-3000
Symmetrical Short Circuit Rating for 2 sec. (RMS), kA	25	25	25	25	40	25	65	40

**Notes:**

- A) The above table is applicable for all ratings of Unit & Package substations.
- B) The Stand-alone L.V panel designs shall be rated by current for dual voltage as indicated in the table as:
- (I) 1600A L.V. panel to be used for 300kVA (400/231, 231/133V), 500kVA (400/231, 231/133V) and 1000kVA (400/231V) transformer ratings, but the outgoing MCCBs shall be as given in the table for each rating.
- (II) 3000A L.V. panel to be used for 1000kVA (231/133V) and 1500kVA (400/231V) transformer ratings, but the outgoing MCCBs shall be as given in the table for each rating.
- (III) 4000A L.V. panel to be used for 1500kVA (231/133V) transformer rating.

**4.11 Grounding:**

- 4.11.1 Two terminals having M12 stud and nut shall be provided on enclosure of the panel with identified clear grounding mark.
- 4.11.2 All hinged parts shall be connected to the frame work (enclosure) through minimum 35mm<sup>2</sup> bolted copper braids.

**4.12 Internal Lighting:**

The L.V. panel shall be fitted with a 100w lamp controlled by a door operated switch. The auxiliary circuit supplying the lamp shall have a separate miniature circuit breaker located in an accessible position.

**4.13 Auxiliary Supply:**

- 4.13.1 A pre-wired terminal block near the right bottom of the panel for 3 phase, 4-wire connections shall be installed. The terminals size shall be suitable for 10mm<sup>2</sup> standard wiring. 10A miniature circuit breakers shall be provided in the circuit.
- 4.13.2 The L.V. panel shall be equipped with a three pin socket outlet 220V complete with plug top and labeled with the appropriate voltage. The position of the socket outlet shall not impede cable installation or termination. Wiring shall be 4mm<sup>2</sup> copper, 85°C black PVC insulation with crimping type connectors.

**4.14 L.V. Cable Support:**

- 4.14.1 Steel cable supports and wooden or non ferrous clamps shall be provided and fixed above L.V. panel base frame just below cable break-out position. They shall be adequate to support the cable in normal service and when subjected to short circuit tests (See Figure 3). L.V. panel base frame cover fabricated in two half plate divided into three sections for easy installation and removal of outgoing cables and with sealable cable entry holes shall be provided.
- 4.14.2 Adequate vertical (at least 50cm. above cable clamps) and horizontal spacing shall be provided to permit connection of the phase conductors on MCCB terminals, whatever their formation. All L.V. cables shall be terminated from front in a horizontal plane at one level and clamped inside L.V. Panel.



#### 4.15 Labels:

- 4.15.1 Each outgoing circuit shall be numbered in sequence from right to left facing the L.V. panel.
- 4.15.2 Numbers shall be engraved on three layers trafolyte plate (white/black/white) of 3mm thickness of dimension 30mm x 80mm. These labels shall be fixed above the MCCB in suitable place.
- 4.15.3 Insertion Pocket for circuit number plate/sheet (as per Figure 4) shall be provided in the left door of the panel.

#### 4.16 Enclosure:

The enclosure shall be designed as follows:

- 4.16.1 Weather proof and provided with watershed top. Enclosure shall be of galvanized sheet steel at least 3mm or Aluzinc at least 2 mm. thick.
- 4.16.2 Adequate ventilation shall be provided by means of canopy, louvers...etc. to allow natural circulation of air. Ventilation shall be suitably screened to prevent the entry of insects and foreign bodies. Screen material shall be made of strong enough stainless steel. Degree of protection shall be IP 54, IP 43 of IEC 60529 for Outdoor, Indoor applications respectively.
- 4.16.3 For stand-alone L.V. panel enclosure shall be suitable for mounting on a flat base at ground level. Holes shall be provided for fixing M16 size foundation bolts.
- 4.16.4 Access to the L.V. panel shall be from the front by means of gasketed/hinged doors fitted with locking bar to secure them at the top and bottom and one stainless steel hasp set for separate pad locking.
- i) Hinges shall be fitted by bolts made from stainless steel or brass.
  - ii) Pressure fit type gasket shall be provided. Glue fit type is not acceptable.
  - iii) Locking shall be as follows :
    - Handle shall be high grade stainless steel.
    - Shall be operated by central handle.
    - Handle shall have integral lock and shall be inaccessible by means of stainless steel pivoted cover with a hasp for padlocking both doors as shown in Figure (6).



- Integral lock cylinder type and manufacturer shall be as approved by SEC.
- Locking rotation shall be maintained within 90 degrees.
- Top and bottom locking bars shall be provided with roller for each engagement of the locking bars with the panel frame.
- iv) Stainless steel hasp and cover set for padlock shall be 3 mm thick.
- v) Fitted with lifting device at both side, and located such that the unit is balanced when lifted.

4.16.5 All doors shall be provided with door stoppers and locking at open position to protect from swinging in order to avoid accidents.

4.16.6 Finishing Color:

The enclosure shall be adequately protected against corrosion and painted as per SEC specification 01-SDMS-01.

#### 4.17 Dimensions:

Maximum overall dimensions for stand-alone L.V. Panel shall be as follows:

Source Rating	Length (mm)	Width (mm)	Height (mm)
1600 A	1800	550	1900
3000 A	2000	550	1900
4000 A	2500	650	1900

#### 5.0 NAME PLATE:

Each panel shall be provided with an aluminum name plate fixed inside on left door bearing the following informations engraved on it as minimum in Arabic and in English.

- Reference to SEC specification
- Rated voltage (V)
- Rated current of busbar (A)
- Rated current of incoming unit (A).
- Rated current of outgoing unit (A).
- Short circuit current rating (kA)
- SEC purchase order number
- SEC item number
- Manufacturer's / Vendor's name
- Year of manufacture
- Gross weight when fully equipped (kg)
- Serial number



## 6.0 MONOGRAM & DANGER PLATES:

Danger plate and SEC monogram as per SEC drawings No. SEC-01-01 and SEC-01-02 respectively shall be provided and installed at the front (on SEC approved location) of the L.V. Panel using M5 hot dipped galvanized/stainless steel/brass fasteners (oval head rounded neck bolts with nuts and external tooth lock washers) not removable/accessible from the front i.e. without opening the door/front cover.

SEC shall approve location and samples of danger and monogram plates prior to installation.

## 7.0 TESTING:

Panels shall be tested in accordance with the latest standards and as specified herein. All test results shall be provided for review and acceptance by SEC.

### 7.1 Type (Design) Test:

#### 7.1.1 Short Circuit Test:

The panel shall be capable of carrying the short circuit current (rms, symmetrical) for two seconds.

#### 7.1.2 Temperature Rise Test:

- a) Temperature rise test shall be conducted as per IEC 60439-1.
- b) Temperature rise test at any point shall not exceed 60°C relevant to the maximum ambient temperature as specified in SEC specification 01-SDMS-01.
- c) For Instruments inside the panel, the temperature rise shall not exceed the allowable temperature of the instruments.

#### 7.1.3 Salt Spray Test and Tape (Scratch) Test shall be as given in SEC specification 01-SDMS-01.

#### 7.1.4 Certified test reports of Design test performed on an identical unit shall be submitted to SEC for review and approval during bidding stage.

## 7.2 Routine Test:

All Routine Tests prescribed in the relevant IEC shall be performed on all units prior to delivery to SEC.

**8.0 INSPECTION:**

SEC may wish to witness tests or to visit factory during manufacture of any or all items covered in this specification. Accordingly the supplier shall give advance notice to SEC of the manufacturing and test schedule.

**9.0 PACKING AND SHIPPING:**

Packing and shipping shall generally be as per SEC General Requirements 01-SDMS-01 including the following:

- 9.1 The panel shall be delivered ready for service.
- 9.2 Supplier shall contact Materials Department of SEC for additional packing, handling and shipment instructions as applicable.
- 9.3 Packing crates shall be marked with following :
  - Manufacturer's name
  - Country of origin
  - SEC purchase order number
  - SEC item number
  - Gross weight in kilograms
  - Handling instructions
  - Final destination store

**10.0 GUARANTEE:**

The vendor shall guarantee the panel against all defects arising out of faulty design or workmanship or defective materials for a period of two years from the date of delivery.

**11.0 SUBMITTALS:**

- 11.1 The vendor shall fill and submit one copy of the attached Technical Data Schedule with the quotation. In addition to Data Schedule, clause by clause compliance to this specification shall also be confirmed/submitted.
- 11.2 Detailed dimensional drawings of the panel, showing all mounting arrangements, terminals, electrical clearances between phase and earth, hinges, cable clamps, locking arrangement and name plate shall be submitted.



- 11.3 Single line diagram shall be submitted.
- 11.4 The supplier shall provide literature describing field experience under similar service conditions to those in section 4.0. A reference sale list shall be included. This shall detail the quantities sold, name and address of the user, number of years in service, in each case.
- 11.5 A comprehensive list of manufacturer's recommended spare parts with full details (item description, part no., manufacturer name, supplier name ...etc) shall be submitted separately
- 11.6 Catalogue that indicates part nos. of all the components inside the panel shall be submitted.
- 11.7 Detail drawing showing the installation of revenue metering CT as required in this specification.

**DATA SCHEDULE****Low Voltage Distribution Panel (Sheet 1 of 3)**

SEC Inquiry No. \_\_\_\_\_

Item No. \_\_\_\_\_

Clause	DESCRIPTION	SEC SPECIFIED VALUES	VENDOR PROPOSED VALUES
<b>4.0</b>	<b>DESIGN AND CONSTRUCTION REQUIREMENTS</b>		
<b>4.1</b>	<b>General</b>		
	Rated voltage	231V/133V, ±5%	
		400V/231V, ±5%	
	Symmetrical Short Circuit Rating for 2 seconds (rms)	kA	
	Phase busbar rating	(A)	
	Neutral busbar rating	(A)	
4.1.8	Min. clearance between phases and phase to ground	25.4 mm	
<b>4.2</b>	<b>Incoming Transformer Connection</b>		
4.2.1	Removable copper links		
4.2.3	No. of incoming cables (for Stand-alone)	As per Table-1	
<b>4.3</b>	<b>Busbars</b>		
4.3.1	Material	Tinned Copper	
	Min thickness of tin plating	5% of nominal composition	
4.3.2	Size of phase busbar		
4.3.3	Electrical joints (bolts, nuts, washers)	Plated as per 01-SDMS-01	
4.3.4	Insulating barrier to cover live parts		
4.3.5	Busbar color	Red/Yellow/Blue Black for neutral	
<b>4.4</b>	<b>Provision for generator connection</b>	Yes	
<b>4.5</b>	<b>Size of neutral busbar</b>		
<b>4.6</b>	<b>Current Transformer :</b>		
	Class	0.5	
	Burden	10 VA	
	Error co-efficient	< 5	
	Insulation class	Class E-120°C	
	Type and make		

**DATA SCHEDULE****Low Voltage Distribution Panel (Sheet 2 Of 3)**

SEC Inquiry No. \_\_\_\_\_

Item No. \_\_\_\_\_

Clause	DESCRIPTION	SEC SPECIFIED VALUES	VENDOR PROPOSED VALUES
<b>4.7</b>	<b>Ammeters:</b> Type and make		
4.7.2	Scale	As per Table-1	
4.7.3	Size	96mm x 96mm	
<b>4.8</b>	<b>Voltmeters:</b> Type and make		
4.8.1	Scale	0-300 V / 0-500 V	
4.8.2	Size	96mm x 96mm	
<b>4.9</b>	<b>KWH-Meter Wiring Provision</b>		
<b>4.11</b>	<b>Outgoing MCCB's:</b> Type, Model & Make Rated current Dimensions(L x W x D) mm No. of supplied MCCB's No. of provisions for fixing MCCB's	400 A	
<b>4.12</b>	<b>Grounding :</b> Two terminals of M12 stud Copper braid for hinged parts	Yes 35mm <sup>2</sup>	
<b>4.13</b>	<b>Internal Lighting</b>	100W	
<b>4.14</b>	<b>Auxiliary Supply:</b>		
<b>4.15</b>	<b>L.V. Cable Supports</b>		
<b>4.16</b>	<b>Labels</b>		
<b>4.17</b>	<b>Enclosure:</b> Material Thickness of sheet Degree of protection Type of gasket Locking arrangement  Finishing color	Steel sheet/Aluzinc 3mm/2mm IP54/IP43 Pressure fit clause 4.17.4 As per 01-SDMS-01	
<b>4.18</b>	<b>Dimensions L x W x H (mm) (for Stand-alone L.V. panel)</b>		
<b>6.0</b>	<b>MONOGRAM &amp; DANGER PLATES</b>	Yes	

**DATA SCHEDULE****Low Voltage Distribution Panel (Sheet 3 of 3)**

SEC Inquiry No. \_\_\_\_\_ Item No. \_\_\_\_\_

- A. Additional technical information or features specified by SEC:
- B. Additional supplementary data or features proposed by vendor/supplier:
- C. Other particulars to be filled up by vendor/supplier:  
(use separate sheet if needed)

Address	Manufacturer	Vendor/Supplier
Name of Company		
Location and Office Address		
Authorized Name and Signature		
Date		
Official seal / stamp		

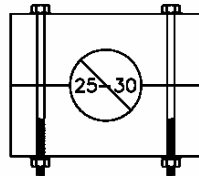

WOODEN CABLE CLAMPS FOR AUXILIARY SUPPLY CABLES

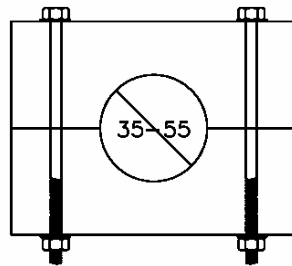

WOODEN CABLE SUPPORTS FOR INCOMING CABLES

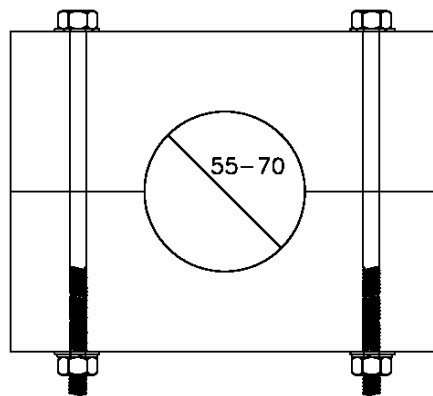

WOODEN CABLE SUPPORTS FOR OUTGOING CABLES

**FIG-3: WOODEN CABLE CLAMPS**

ALL DIMENSIONS ARE IN MILLIMETER



CIRCUIT NUMBER	DESCRIPTION
1	
2	
3	
4	
5	
6	
7	
8	
9	
10	
11	
12	

**NOTE**

TABLE SIZE SHALL BE PROPORTIONAL TO THE INSIDE OF THE LEFT SIDE DOOR OF THE PANEL

**FIG-4: CIRCUITS LABEL**

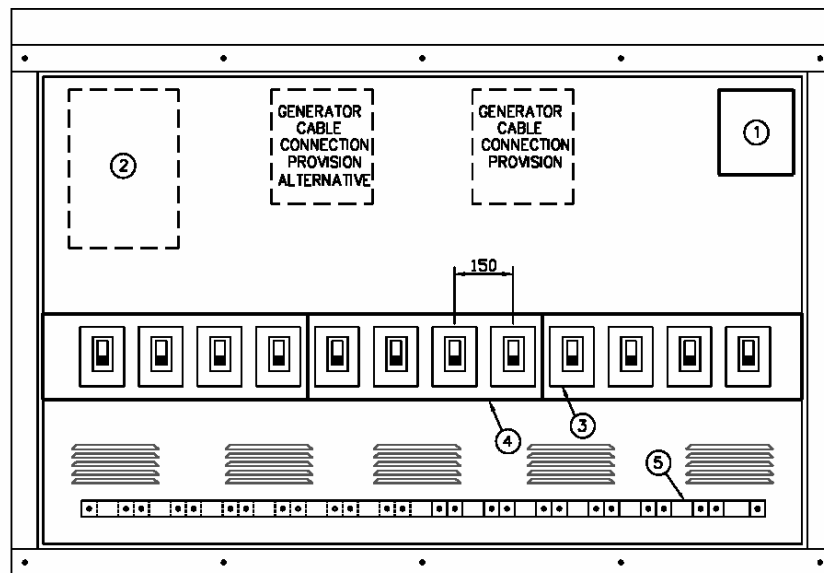

**LEGEND**

- ① INSTRUMENTS (INDICATING METERS & SELECTION SWITCHES)
- ② ACCESS TO (TEMPERATURE INDICATOR, OIL LEVEL INDICATOR & TAP CHANGER)
- ③ OUTGOING MCCB
- ④ SAFETY COVER
- ⑤ HARDWOOD CABLE SUPPORTS

**FIG-5: LOW VOLTAGE DISTRIBUTION PANEL WITH DOOORS OPEN**

ALL DIMENSIONS ARE IN MILLIMETER

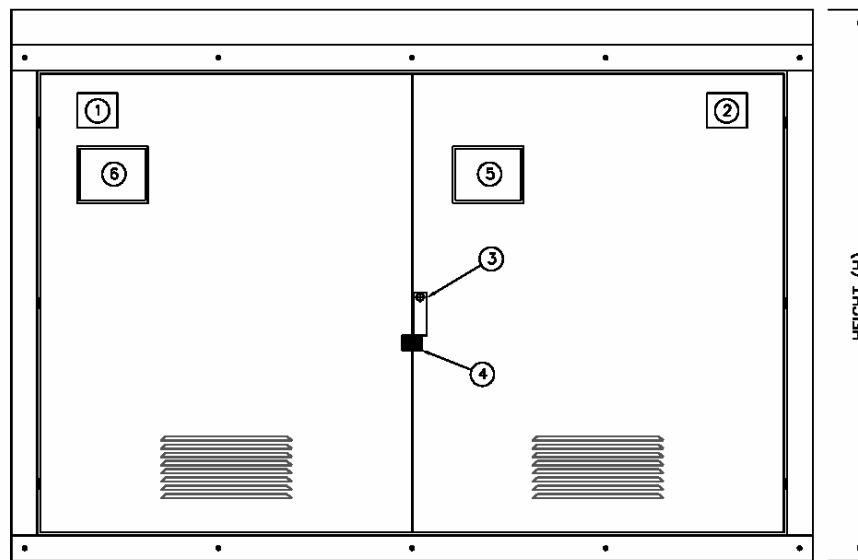

**LEGEND**

- ① SEC DANGER PLATE
- ② SEC MONOGRAM PLATE
- ③ DOOR HANDLE COVER
- ④ PAD LOCKING PROVISION
- ⑤ GENERATOR CABLE ENTRY WINDOW LOCATION COVERED WITH STEEL PLATE
- ⑥ GENERATOR CABLE ENTRY WINDOW COVERED WITH STEEL PLATE (ALTERNATIVE)

**FIG-6: LOW VOLTAGE DISTRIBUTION PANEL WITH DOOORS CLOSED**

ALL DIMENSIONS ARE IN MILLIMETER