

**SPECIFICATION FOR DISTRIBUTION
TRANSFORMERS W/ ALUMINUM
WINDINGS INCLUDING
DUAL PRIMARY W/ DUAL SECONDARY**

Issue Date: 16/7/2019 **Page:** 1 of 29

51-SDMS-04 REV.02

51-SDMS-04

Rev.02

SPECIFICATION FOR DISTRIBUTION TRANSFORMERS WITH ALUMINUM WINDINGS RATED 11KV UP TO 36KV INCLUDING DUAL PRIMARY WITH 400/230V & 230/133V DUAL SECONDARY

This document contains proprietary information developed by and for exclusive use of Saudi Electricity Company (SEC) Distribution Network. Your acceptance of the document is an acknowledgment that it must be used for the identified purpose/application and during the period indicated. It cannot be used or copied for any other purposes nor released to others without prior written authorization of SEC Distribution Services Sector. SEC shall assume no responsibility for any type of misuse and/or misapplication, and any harm resulting there from. SEC also reserves the right to take any necessary actions to protect its interest against unauthorized use.

**SPECIFICATION FOR DISTRIBUTION
TRANSFORMERS W/ ALUMINUM
WINDINGS INLCUDING**

DUAL PRIMARY W/ DUAL SECONDARY

Issue Date: 16/7/2019

Page: 2 of 29

51-SDMS-04 REV.02

51-SDMS-04

Rev.02

**SPECIFICATION FOR DISTRIBUTION TRANSFORMERS
WITH ALUMINUM WINDINGS RATED 11KV UP TO 36KV
INCLUDING DUAL PRIMARY WITH 400/230V & 230/133V
DUAL SECONDARY**

**SPECIFICATION FOR DISTRIBUTION
TRANSFORMERS W/ ALUMINUM
WINDINGS INLCUDING
DUAL PRIMARY W/ DUAL SECONDARY**

Issue Date: 16/7/2019 **Page:** 3 of 29

51-SDMS-04 REV.02

Revision History

#	Date	Revision No.	Revised By	Major Revision Description
1				
2				
3				
4				
5				
6				
7				
8				
9				
10				

**SPECIFICATION FOR DISTRIBUTION
TRANSFORMERS W/ ALUMINUM
WINDINGS INLCUDING
DUAL PRIMARY W/ DUAL SECONDARY**

Issue Date: 16/7/2019 **Page:** 4 of 29

51-SDMS-04 REV.02

Table of Contents

1	Scope.....	5
2	Cross references to other SEC standards	5
3	Applicable codes and standards	5
4	Service and system conditions	6
5	Material, design and construction requirements	6
5.1	General	6
5.2	Design criteria	7
6	Marking.....	14
7	Testing and inspection	15
7.1	Routine Tests.....	15
7.2	Type tests.....	16
7.3	Sample inspection	16
8	Packing and shipping	16
9	Guarantee	17
10	Submittals	17
10.1	Submittals required with tender/inquiry	17
10.2	Submittals required following award of contract	18
11	Technical data schedule	19
12	Drawings	19

**SPECIFICATION FOR DISTRIBUTION
TRANSFORMERS W/ ALUMINUM
WINDINGS INCLUDING
DUAL PRIMARY W/ DUAL SECONDARY**

Issue Date: 16/7/2019 **Page:** 5 of 29

51-SDMS-04 REV.02

1 Scope

This specification defines the minimum technical requirements for design, engineering, manufacturing, testing, inspection and performance of insulating fluid-immersed, hermetic-type, step-down 3-phase distribution transformers with aluminum windings with 11kV up to 36kV including dual-voltage primary and 400/230V & 230/133V dual secondary intended to be used in the distribution network of Saudi Electricity Company (SEC) in Saudi Arabia.

2 Cross references to other SEC standards

This specification shall always be read in conjunction with SEC General Specification No. 01-SDMS-01 (latest revision) titled "General Requirements for all Equipment/Materials," which shall be considered as an integral part of this specification. It shall also be read in conjunction with SEC purchase order and/or contract schedules, and scope of work/technical specifications for projects, as applicable.

3 Applicable codes and standards

The latest revision of the following codes and standards shall be applicable for the equipment/materials covered in this specification. In case of any deviation, the vendor/manufacturer may propose equipment/materials conforming to alternate codes or standards. However, the provisions of SEC standards shall supersede the provisions of these alternate standards in case of any difference.

Standard #	Title
IEC 60076-1	Power Transformers – Part 1: General
IEC 60076-2	Power Transformers – Part 2: Temperature-Rise for Liquid-Immersed Transformers
IEC 60076-3	Power Transformers – Part 3: Insulation Levels, Dielectric Tests and External Clearances in Air
IEC 60076-5	Power Transformers – Part 5: Ability to Withstand Short-Circuit
IEC 60076-7	Power Transformers – Part 7: Loading Guide for Mineral Oil-Immersed Power Transformers
IEC 60076-10	Power Transformers – Part 10: Determination of Sound Levels
IEC 60137	Insulated Bushings for Alternating Voltages Above 1000V
IEC 60214-1	Tap-Changers – Part 1: Performance Requirements and Test Methods
IEC 60296	Fluids for Electrotechnical Applications – Unused Mineral Insulating Oils for Transformers and Switchgears
IEC 62770	Fluids for Electrotechnical Applications – Unused Natural Esters for Transformers and Similar Electrical Equipment

**SPECIFICATION FOR DISTRIBUTION
TRANSFORMERS W/ ALUMINUM
WINDINGS INCLUDING
DUAL PRIMARY W/ DUAL SECONDARY**

Issue Date: 16/7/2019 **Page:** 6 of 29

51-SDMS-04 REV.02

Standard #	Title
IEC 61099	Insulating Liquids – Specifications for unused Synthetic Organic Esters for Electrical Purposes
IEC 60060	High-Voltage Test Techniques
IEC 62217	Polymeric HV Insulators for Indoor and Outdoor Use – General Definitions, Test Methods and Acceptance Criteria
IEC TS 60815-3	Selection and Dimensioning of High-Voltage Insulators Intended for Use in Polluted Conditions – Part 3: Polymer Insulators for AC Systems
EN 50180	Bushings Above 1kV up to 52kV and from 250A to 3,15kA for Liquid Filled Transformers

Table 1: List of applicable standards

4 Service and system conditions

The distribution transformers shall be suitable for operation under the service conditions specified in the latest revision of SEC specification 01-SDMS-01.

All fittings and attachments of the distribution transformers shall be capable of withstanding the effects of direct solar radiation at their installed locations. The temperature of surfaces exposed to direct solar radiation shall be regarded as 75°C plus the effect of any internal heating.

5 Material, design and construction requirements

5.1 General

- 5.1.1 The distribution transformers shall meet or exceed the requirements of this specification in all respects and it shall be manufactured and tested in conformance with relevant international standards.
- 5.1.2 Manufacturer's drawing shall show the outline of the distribution transformers together with all pertinent dimensions, associated components/parts, and base and/or mounting accessories. Any variations in these dimensions due to manufacturing tolerances shall be indicated.
- 5.1.3 The distribution transformers shall be indoor/outdoor type, step-down, 3-phase transformers with two separate insulating fluid-immersed aluminum windings sealed hermetically in a mild steel tank. It shall be suitable for pole or pad mounting, where for pad-mounted transformers: the primary and secondary bushings are side-mounted inside the cable boxes, and for pole-mounted transformers: the primary bushings are mounted on open top of the tank and the secondary bushings are side-mounted inside a cable box.

SPECIFICATION FOR DISTRIBUTION TRANSFORMERS W/ ALUMINUM WINDINGS INCLUDING DUAL PRIMARY W/ DUAL SECONDARY

Issue Date: 16/7/2019 **Page:** 7 of 29

51-SDMS-04 REV.02

5.2 Design criteria

5.2.1 Ratings - distribution transformers conforming to this specification shall be designed with dual switchable secondary voltages of 400/230V and 230/133V with the standard ratings as shown in Table 2.

Transformer Type	Standard kVA Ratings
Pole-Mounted	100, 200, 300
Pad-Mounted	300, 500, 1000, 1500

Table 2: Distribution transformer standard kVA ratings

The kVA ratings of the transformers shall be calculated based on the following assumptions:

- a. Constant Flux Regulation
- b. Continuous Steady Load
- c. Design Temperature of 35°C (based on yearly average temperature)
- d. Average Winding and Top-Oil Temperature-Rise Limits Above 50°C and 45°C Ambient Temperature, respectively
- e. Maximum Winding Hot-Spot Temperature of 98°C

5.2.2 Losses – the acceptable maximum losses of the transformers shall be as shown in Table 3. Any transformer unit exceeding the allowable maximum losses will be rejected.

Transformer Rating, kVA	No-Load Losses, Watts	Load Losses, Watts
100	250	1500
200	380	2200
300	520	3200
500	750	4700
1000	1100	9000
1500	1700	14000

Note: No-load and load losses (referred at 400V) submitted in the tender shall be treated as guaranteed value, any increase in these values at the time of testing shall not be accepted.

Table 3: Distribution transformers allowable maximum losses

SPECIFICATION FOR DISTRIBUTION TRANSFORMERS W/ ALUMINUM WINDINGS INCLUDING DUAL PRIMARY W/ DUAL SECONDARY

Issue Date: 16/7/2019 Page: 8 of 29

51-SDMS-04 REV.02

5.2.3 Emergency Loading – after thermal equilibrium has been reached at 75% of rated load, the transformer shall be capable of sustaining the overload conditions listed in Table 4 without the transformer winding hot-spot temperature exceeding 140°C.

Loading Percentage of Transformer Rating, %	Minimum Duration in Minutes at Ambient Temperature	
	30°C	40°C
133	240	155
150	98	65

Note: The supplier shall demonstrate by test and calculation that these requirements are met.

Table 4: Distribution transformers overloading schedule

5.2.4 Cooling – the type of cooling of the distribution transformers shall be ONAN.

5.2.5 Insulating Fluid – unless otherwise specified, the transformers shall be supplied pre-filled with Class 1 uninhibited mineral oil complying with IEC 60296.

Other types of insulating fluids are natural or synthetic esters complying with IEC 62770 and IEC 61099, respectively.

5.2.6 Tap-Changer and Connecting Links:

Tap-Changer - the transformer shall be fitted on the primary side with a lockable 5-position, manually operated, off-load tap-changer having the following taps as shown in Table 5.

Tap Number	Percentage Taps of the Rated Voltage
1	+5 %
2	+2½ %
3	0 %
4	-2½ %
5	-5 %

Table 5: Distribution transformers tapping

LV Connecting Links – all distribution transformers with dual secondary voltages shall have only four low-voltage bushings inside the secondary cable box. The changing of the secondary voltage shall be of simple arrangement without the need of opening the secondary cable box or disconnecting the termination of the

SPECIFICATION FOR DISTRIBUTION TRANSFORMERS W/ ALUMINUM WINDINGS INCLUDING DUAL PRIMARY W/ DUAL SECONDARY

Issue Date: 16/7/2019 **Page:** 9 of 29

51-SDMS-04 REV.02

low-voltage cables. It shall be done easily by repositioning a single change-over link in an air-filled sealed box at the top of the tank to select either 400/230V or 230/133V preferably by joining the respective neutral terminals through that link.

The change-over sealed box at the top of the tank shall be so arranged that it shall indicate the internally connected voltage-ratio and is clearly readable from the outside.

Default connection of the secondary change-over link is on 400/230V.

- 5.2.7 Vector Group - unless otherwise specified, the transformer shall be connected delta-star in accordance with vector group reference Dyn11.
- 5.2.8 Impedance Voltage - at normal tap shall be 4% for transformers rated up to 300kVA, 5% for 500kVA, and 6% for transformers rated more than 500kVA.
- 5.2.9 Temperature-Rise - at rated power, the transformer shall comply with the following maximum temperature-rise limits.

Top-Oil Temperature-Rise	45°C
Winding Temperature-Rise	50°C
Hot-Spot Temperature	98°C
Average Temperature due to Short-Circuit	200°C

Table 6: Maximum temperature-rise limits of distribution transformers

- 5.2.10 Noise Level – as emitted by the transformer at full-load shall not exceed 48dB. Measurements shall be in accordance with IEC 60076-10.
- 5.2.11 Short-Circuit Level - the transformers shall withstand the short-circuit currents as shown in Table 7 for a minimum duration of 2 seconds.

Transformer Rating, kVA	Short-Circuit Current Withstand, kA
100, 200, 300	25 x Full-load Current
500	20 x Full-load Current
1000, 1500	17 x Full-load Current

Table 7: Short-circuit current withstand of distribution transformers

- 5.2.12 IP Protection - the transformer and its cable-boxes shall be designed to have ingress protection level suitable for outdoor applications.

**SPECIFICATION FOR DISTRIBUTION
TRANSFORMERS W/ ALUMINUM
WINDINGS INCLUDING
DUAL PRIMARY W/ DUAL SECONDARY**

Issue Date: 16/7/2019 **Page:** 10 of 29

51-SDMS-04 REV.02

5.2.13 Dimensions - the maximum allowable dimensions of the transformers shall be as per Table 8.

Transformer Rating, kVA		Dimensions, mm		
		Width	Depth	Height
Pole-Mounted	100	1350	900	1600
	200	1450	1100	1700
	300	1450	1100	1700
Pad-Mounted	300	1700	1500	1600
	500	1700	1600	1700
	1000	1900	1800	1900
	1500	1920	1900	2200

Note: The above dimensions are not applicable for transformers used in unit substations.

Table 8: Maximum allowable dimensions of distribution transformers

5.2.14 Tank Fabrication - transformer tanks shall be made of mild steel 3mm thick, and shall not leak. The criterion of leakage shall be discoloration by oil of white wash applied externally to the suspended part at an oil temperature 90°C or other method approved by SEC.

All pipes, radiator fins, or corrugations that are welded to the tank shall be externally welded.

The tank shall be of hermetically sealed construction, and shall withstand an internal pressure of 30kN/m² without permanent deformation.

Top cover shall be bolted-type and fitted with neoprene cork seals suitable for temperatures as specified in this specification. The cover shall be in such a design and construction as to prevent the ingress of moisture and accumulation of rainwater.

5.2.15 Tank Corrosion Protection and Finish - the transformer tank and its accessories including bolts and fittings shall be suitably protected against corrosion.

Hot-dip galvanizing followed by painting is the preferred method of base protection. Otherwise tanks shall be shot-blasted and then immediately zinc sprayed to an average weight deposit of not less than 550g/m², followed by zinc or zinc chromate based primary paint, and two coats of durable oil and weather resisting paint. Finish color shall be Light Grey (RAL 7035).

**SPECIFICATION FOR DISTRIBUTION
TRANSFORMERS W/ ALUMINUM
WINDINGS INCLUDING
DUAL PRIMARY W/ DUAL SECONDARY**

Issue Date: 16/7/2019 **Page:** 11 of 29

51-SDMS-04 REV.02

5.2.16 Primary Bushings / Terminals – shall generally comply with the requirements of IEC 60137, IEC 62217, and EN 50180 as applicable.

The primary bushings shall be labeled U, V, W by using indelible black color paint. Phase identification using adhesive stickers is not acceptable.

- A. Pole-Mounted Transformers – the primary bushings shall be weather-proof polymer-type with grey color single-piece housing and hydrophobic sheds that are designed to minimize trapping of contamination of dust, sands, moisture, etc. Housing is made of UV-resistant high-temperature vulcanized silicon rubber.

The primary bushings shall be fitted on top of the transformer tank and are provided with M12 threaded stems with nuts and washers.

- B. Pad-Mounted Transformers – the primary bushings shall be epoxy-resin Type-C1 bushings in conformance with EN 50180 fitted on the side of the transformer tank inside a cable box with cable entry coming vertically from the bottom.

The cable box shall include cable clamps, grounding connectors, and its size shall be adequate for terminating 3 x single-core or 1 x three-core medium-voltage power cables per SEC specification 11-SDMS-03, sizes are either 50mm² copper or 70mm² aluminum with the use of T-Type separable elbow connector per latest revision of 12-SDMS-01. The cable box shall have a single gasket, removable, bolted-type cover. Its bottom plate shall be in two halves with cable entry steel knockouts suitable for the aforementioned cables. Loose rubber bushings shall be provided inside the cable box for the knockouts.

5.2.17 Secondary Bushings / Terminals – the low-voltage leads of all distribution transformers shall be made of aluminum and be brought out on the side of transformer tank in a cable box where cable entries are coming vertically from the bottom.

The low-voltage cable box shall have removable, single-gasket, bolted front cover. Its bottom plate shall be in two-halves with cable entry steel knockouts suitable for passing SEC cables. Loose rubber bushings shall be provided inside of the box for the easily detachable knockouts.

The secondary bushings shall be provided with complete fittings (suitable bolts, nuts, and washers) for SEC cable connections, and labeled n, u, v, w from right to left by using indelible black color paint. Phase identification using adhesive stickers are not acceptable.

**SPECIFICATION FOR DISTRIBUTION
TRANSFORMERS W/ ALUMINUM
WINDINGS INCLUDING
DUAL PRIMARY W/ DUAL SECONDARY**

Issue Date: 16/7/2019 **Page:** 12 of 29

51-SDMS-04 REV.02

- A. Pole-Mounted Transformers – the terminals of the secondary bushings shall be suitable to connect the aluminum cables as specified in Table 9.

Transformer Rating, kVA	Number of Cables that can be Connected
100	1 x (4C x 185mm ²)
200	2 x (4C x 185mm ²)
300	2 x (4C x 185mm ²) for 400V 2 x (4C x 300mm ²) for 230V

Note: Cable lugs shall comply with the latest revision of SEC specification 12-SDMS-02, and 11-SDMS-01 for the low-voltage cables.

Table 9: Allowable aluminum cables to be connected to pole-mounted transformers

- B. Pad-Mounted Transformers – the cable box for the secondary bushings shall be located on the opposite side of the cable box for the primary bushings.

The terminals of the secondary bushings shall be suitable for connecting copper or aluminum cables as specified in Table 10.

Transformer Rating, kVA	Cable Conductor Material	Number of Cables that can be Connected per Phase	Number of Cables that can be Connected on the Neutral
300	Copper	1 x (1C x 630mm ²)	1 x (1C x 630mm ²)
	Aluminum	1 x (1C x 1000mm ²)	1 x (1C x 1000mm ²)
500	Copper	1 x (1C x 630mm ²) 400V 2 x (1C x 630mm ²) 230V	1 x (1C x 630mm ²)
	Aluminum	1 x (1C x 1000mm ²) 400V 2 x (1C x 1000mm ²) 230V	1 x (1C x 1000mm ²)
1000	Copper	2 x (1C x 630mm ²) 400V 4 x (1C x 630mm ²) 230V	1 x (1C x 630mm ²) 400V 2 x (1C x 630mm ²) 230V
	Aluminum	2 x (1C x 1000mm ²) 400V 4 x (1C x 1000mm ²) 230V	1 x (1C x 1000mm ²) 400V 2 x (1C x 1000mm ²) 230V
1500	Copper	3 x (1C x 630mm ²) 400V 6 x (1C x 630mm ²) 230V	2 x (1C x 630mm ²) 400V 3 x (1C x 630mm ²) 230V
	Aluminum	3 x (1C x 1000mm ²) 400V 6 x (1C x 1000mm ²) 230V	2 x (1C x 1000mm ²) 400V 3 x (1C x 1000mm ²) 230V

Note: Cable lugs shall comply with the latest revision of SEC specification 12-SDMS-02, and 11-SDMS-01 for the low-voltage cables.

Table 10: Allowable copper/aluminum cables to be connected to pad-mounted transformers

**SPECIFICATION FOR DISTRIBUTION
TRANSFORMERS W/ ALUMINUM
WINDINGS INCLUDING
DUAL PRIMARY W/ DUAL SECONDARY**

Issue Date: 16/7/2019 **Page:** 13 of 29

51-SDMS-04 REV.02

5.2.18 Supplementary Fittings:

- 5.2.18.1 Mounting Bracket for Surge Arresters – pole-mounted transformers shall be provided with mounting bracket for surge arresters fitted on top cover with a distance between the mounting points equal or greater than the center-to-center distance of the primary bushings. Mounting holes of the surge arrester mounting bracket shall be 14mm, as shown in Figure 1.
- 5.2.18.2 Temperature Indicator – it shall be removable dial-type thermometer fitted on the thermometer pocket mounted on top of the transformer tank. It shall have a range of 0°C to 120°C and so positioned that oil temperature reading is visible from the ground level.
- 5.2.18.3 Pressure-Relief Vent – it shall be provided to prevent transformer ruptures in case the transformer abnormally builds-up internal pressure. However, it shall be capable of withstanding the variations of pressure at normal operation.
- 5.2.18.4 Oil Level Indicator – a sight glass or dial-type oil level indicator shall be fitted on the same side of the transformer tank where the tap-changer control handle is located. The indicator should be visible from the ground level.
- 5.2.18.5 Lifting Lugs – it shall be permanently attached and positioned on the tank to provide a distributed/balanced vertical lift on the completely assembled transformer. Lifting lugs shall be designed to have a safety factor of 3.0 where the total mass or load was assumed that the transformer is completely assembled and filled with insulating fluid. The safety factor is the ratio of the ultimate stress of the material used to the working stress, where the working stress is the maximum combined stress developed in the lifting provision by the static load of the completely assembled transformer filled with insulating fluid.
- 5.2.18.6 Tank Earthing – for pole-mounted transformers, 2 x M12 stainless steel earthing studs with nuts and washers shall be provided and positioned diagonally opposite on the tank. For pad-mounted transformers, the earthing studs shall be at the primary side of the transformer to facilitate tank earthing. If the transformer skid base is detachable, then the earthing provisions shall be at the tank wall. Anti-corrosion measures shall be applied to ensure that the tank earthing provisions will avoid corrosions.
- 5.2.18.7 Oil Drain & Filling Facility – oil drain and filling facilities shall be provided.
- The drain pipe size shall be one inch with opening valve and a sealing plug. It shall be provided with removable rigid bumper should/cover for mechanical protection.
- The size of the filling facility shall be one inch with sealing plug.

**SPECIFICATION FOR DISTRIBUTION
TRANSFORMERS W/ ALUMINUM
WINDINGS INCLUDING
DUAL PRIMARY W/ DUAL SECONDARY**

Issue Date: 16/7/2019 **Page:** 14 of 29

51-SDMS-04 REV.02

- 5.2.18.8 Rollers – for pad-mounted transformers, bi-directional rollers with 12.5cm minimum diameters shall be fitted to facilitate site installation. These rollers shall have the option to rotate its position by 90° with a locking facility to secure the transformer in its position, as shown in Figure 2.
- 5.2.18.9 Cable Clamps – all cable clamps provided shall be made of non-ferrous material. For pole-mounted transformers, cable clamps shall be inside the low-voltage cable box.
- Cable clamps shall be sized as per allowable cables mentioned in this specification.
- 5.2.18.10 Mounting – For pole-mounted transformers rated above 100kVA, mounting channels shall be designed with slotted holes suitable to fit transformer platform as shown in Figure 3. For transformers rated 100kVA, support brackets shall be designed as per Figure 4 suitable for single-pole mounting.

6 Marking

Each distribution transformer shall be provided with a clear and durable nameplate made of either aluminum or stainless steel plate with laser etched markings that will remain visible throughout the lifetime of the unit and shall bear the following information:

- a. Manufacturer Name
- b. Manufacturer Serial Number
- c. SEC Serial Number (Information shall be filled by SEC)
- d. Year/Month of Manufacture
- e. Manufacturing Standard, i.e. IEC 60076
- f. Number of Phases, i.e. 3-Phase
- g. Rated Power, (kVA)
- h. Rated Frequency, i.e. 60Hz
- i. Rated Voltages, (kV)
- j. Rated Currents, (A)
- k. Vector Group and Connection Symbol, i.e. Dyn11
- l. Impedance Voltage at Rated Current, (%)
- m. Resistance, (Ohm)
- n. Type of Cooling, i.e. ONAN
- o. Total Mass, (kg)
- p. Total Mass of Core + Windings, (kg)

**SPECIFICATION FOR DISTRIBUTION
TRANSFORMERS W/ ALUMINUM
WINDINGS INCLUDING
DUAL PRIMARY W/ DUAL SECONDARY**

Issue Date: 16/7/2019 **Page:** 15 of 29

51-SDMS-04 REV.02

- q. Winding Material, i.e. Aluminum
- r. Volume of Insulating Fluid, (Liters)
- s. Connection Diagram
- t. Table Showing Tapping Voltages at Each Tapping Positions
- u. Ambient Temperature, (°C)
- v. SEC Issued PO Number
- w. Reference SEC Specification
- x. SEC Item Code
- y. SEC Monogram

Nameplate information/entries that are not fixed shall either be engraved or stamped legibly on the blank entries on the nameplate. Blank fillable entries on the nameplates shall have a black background.

7 Testing and inspection

The distribution transformers shall be tested in conformance with the applicable requirements of IEC 60076.

7.1 Routine Tests

Routine tests in conformance with the applicable clauses of IEC 60076-1 and related parts of IEC 60076 shall be performed on all distribution transformers.

Insulating fluid shall also be tested in conformance with the applicable standards.

Special tests but not limited to temperature-rise test shall also be performed on selected samples.

Electronic copies of the test reports shall be submitted to SEC in USB thumb drive for each batch to be delivered prior to issuance of the releases.

SEC reserves the right to attend the routine tests for each batch of transformers to be delivered. Tests shall be performed either on the whole batch or on randomly selected samples.

SEC may carry out routine tests in its laboratory on random basis on 20% of each batch delivered to SEC warehouses. If one from the 20% failed the test, SEC reserves the right to reject the whole batch. If the 20% passed, SEC may proceed to test any number of transformers from the other 80% of the same batch. From this 80% the supplier/manufacturer shall replace any failed transformer.

**SPECIFICATION FOR DISTRIBUTION
TRANSFORMERS W/ ALUMINUM
WINDINGS INCLUDING
DUAL PRIMARY W/ DUAL SECONDARY**

Issue Date: 16/7/2019 **Page:** 16 of 29

51-SDMS-04 REV.02

7.2 Type tests

Type test shall be performed in complete conformance with the applicable requirements of IEC 60076. It shall be performed at SEC approved laboratories.

SEC reserves the right to attend and witness the tests.

SEC reserves the right to request the supplier/manufacturer to repeat the type test every five (5) years, or as needed should the supplied distribution transformers have frequent faults and failures.

7.3 Sample inspection

Samples together with actual CAD drawings, user manuals and routine test reports shall be subject for inspection/evaluation prior to issuance of approval for mass production.

Sample inspection/evaluation shall be conducted at the manufacturer facilities. The following attributes shall be checked:

- a. Dimensional verification
- b. Routine Tests
- c. Markings
- d. Documentations in English and Arabic, i.e. Operation and Maintenance Manual, Drawings, etc.
- e. Mounting Accessories

8 Packing and shipping

Packing and shipping requirement shall generally be as per latest revision of SEC General Requirements for Equipment/Materials, 01-SDMS-01 or as per purchase order requirements.

Each distribution transformers shall be packed as a complete unit and shall be delivered ready for use.

Packing shall protect the distribution transformers against damage during shipment and site handling.

Suppliers/manufacturers should coordinate with SEC Warehousing Department for additional packing, handling, and or shipping instructions, as applicable.

Packing crates shall be marked with the following information:

- a. Manufacturer's Name and Model/Type
- b. Country of Origin
- c. SEC Purchase Order Number / Tender Number

**SPECIFICATION FOR DISTRIBUTION
TRANSFORMERS W/ ALUMINUM
WINDINGS INCLUDING
DUAL PRIMARY W/ DUAL SECONDARY**

Issue Date: 16/7/2019 **Page:** 17 of 29

51-SDMS-04 REV.02

- d. SEC Item Code
- e. Gross Weight, (kg)
- f. Handling Instructions
- g. Final Destination (SEC Warehouse)

9 Guarantee

The supplier/manufacturer shall guarantee the products against all defects arising out of faulty design or manufacturing defects or defective materials for a period of five (5) years from the date of delivery.

The supplier/manufacturer shall guarantee the uniformity of the products delivered with the approved samples and drawings.

The supplier/manufacturer shall guarantee that the transformers manufactured under this specification are designed to operate normally at an ambient temperature of 55°C in Saudi Arabia environmental conditions.

10 Submittals

10.1 Submittals required with tender/inquiry

- 10.1.1 Summary in table form with the following information: list of items offered, B.O.Q. for each unit offered, manufacturer, origin, catalogue number, and quantity
- 10.1.2 Clause-by-clause compliance with the latest revision of SEC specification 51-SDMS-04
- 10.1.3 Manufacturer's catalogue including those of the transformer components like bushings, temperature indicator, etc., Operation and Maintenance Manual
- 10.1.4 Certificate stating that the raw material has been sampled, tested and inspected in accordance with relevant standard specifications
- 10.1.5 Product type test reports and certificates carried out from SEC approved laboratories
- 10.1.6 Filled-up technical data schedule on each of the items offered, e-copy in Excel (*.xlsx) format

**SPECIFICATION FOR DISTRIBUTION
TRANSFORMERS W/ ALUMINUM
WINDINGS INLCUDING
DUAL PRIMARY W/ DUAL SECONDARY**

Issue Date: 16/7/2019 **Page:** 18 of 29

51-SDMS-04 REV.02

10.1.7 Manufacturer CAD drawings like: transformer outlines showing the position of the fittings and attachments, details of the primary and secondary terminals, mounting arrangements, lifting arrangements, details of the filling and draining valves, cable clamps, etc. E-copies in AutoCAD 2013 (*.dwg) format, for each of the items offered.

10.1.8 USB Flash Drive containing e-copy of all the documents mentioned above

10.2 Submittals required following award of contract

10.2.1 Fabrication CAD drawings

10.2.2 Quality assurance tests

10.2.3 Manufacturing and routine test schedules

10.2.4 Special tests, if applicable

10.2.5 USB Flash Drive containing e-copy of all the documents mentioned above

SPECIFICATION FOR DISTRIBUTION TRANSFORMERS W/ ALUMINUM WINDINGS INCLUDING DUAL PRIMARY W/ DUAL SECONDARY

Issue Date: 16/7/2019 Page: 19 of 29

51-SDMS-04 REV.02

11 Technical data schedule

SEC Inquiry No:

Item No:

No	Description	SEC Specified Values (*)	Vendor Proposed Values (**)
1	General	-	
1.1	Reference Manufacturing Standard	IEC 60076	
2	Design Requirements	-	
2.1	Type of Designation	Pole / Pad Mounted	
2.2	Number of Phase	3	
2.3	Number of Windings	2	
2.4	Material of Windings	Aluminum	
2.5	Rated Frequency, Hz	60	
2.6	Rated Primary Voltage, kV	13.8 / 33 / 34.5 13.8 – 11 (Dual)	
2.7	Rated Secondary Voltage, V (Dual)	400/230 & 230/133	
2.8	Cooling	ONAN	
2.9	Vector Group	Dyn11	
2.10	Impedance Voltage, %	4 / 5 / 6	
2.11	Noise Level, dB	48	
2.12	Short-Circuit Withstand for 2 Seconds, kA		
2.13	Degree of Protection (IP Code)		
3	Insulation Level	-	
3.1	Impulse Withstand Voltages (BIL): - Primary Winding, kV _{peak} - Secondary Winding, kV _{peak}	200 / 170/ 110 / 95	
3.2	Separate-source Power Frequency Test Voltage: - Primary Winding, kV _{rms} - Secondary Winding, kV _{rms}	70 / 38 10 / 3	
3.3	Induces Overvoltage withstand Test: - Primary Winding, kV _{rms} - Secondary Winding, kV _{rms} - Test Frequency, Hz		

SPECIFICATION FOR DISTRIBUTION TRANSFORMERS W/ ALUMINUM WINDINGS INCLUDING DUAL PRIMARY W/ DUAL SECONDARY

Issue Date: 16/7/2019 Page: 20 of 29

51-SDMS-04 REV.02

4	Constructional Features	-	
4.1	Flux Density at Rated Voltage and Frequency, T		
4.2	Specific Loss in Core Laminations, Watt/kg		
4.3	Insulation Core Laminations		
4.4	Winding Conductor Material: - Primary Winding - Secondary Winding	Aluminum Aluminum	
4.5	Winding Conductor Shape: - Primary Winding - Secondary Winding		
4.6	Winding Resistance at 20°C per Phase at Principal Tap: - Primary Winding, Ohm - Secondary Winding, Ohm		
4.7	Maximum Current Densities in Windings at Normal Rating and Principal Tap: - Primary Winding, A/mm ² - Secondary Winding, A/mm ²		
4.8	Material of Winding Insulation		
4.9	Grade and Type of Core		
5	Ratings	-	
5.1	Nominal Transformer Rating at Principal Tapping		
5.2	Normal Rated Current: - Primary, A - Secondary, A		
5.3	Design Continuous Ambient Temperature, °C		
6	Losses	-	
6.1	Core Loss (No-Load Loss), kW _(max)		
6.2	Winding Loss (Load Loss) at 75°C: - Principal Tap, kW _(max) - Tapping with Highest Losses, kW _(max)		
6.3	Magnetizing Current, A		
7	Emergency Loading	-	
7.1	Maximum Duration of Overload at 30°C: - 133%, minutes - 150%, minutes		
8	Insulating Fluid	-	
8.1	Producer	**	

SPECIFICATION FOR DISTRIBUTION TRANSFORMERS W/ ALUMINUM WINDINGS INCLUDING DUAL PRIMARY W/ DUAL SECONDARY

Issue Date: 16/7/2019 Page: 21 of 29

51-SDMS-04 REV.02

8.2	Origin	**	
8.3	Product Name / Trademark	**	
8.4	Type	Mineral Oil Class 1 Uninhibited or As Specified	
8.5	Applicable Standard	IEC 60296 / ASTM D3487 / IEC 62770 / IEC 61099	
9	Tap Changer	-	
9.1	Type	**	
9.2	Make	**	
9.3	Rated Current, A	**	
9.4	Rated Step Voltage, V	**	
9.5	Voltage Class, kV	**	
9.6	Taps (Off-load) on Primary: - Tapping Range, ±% - Number of Taps - Plus Steps, % - Minus Steps, %	5 5 +2.5, +5 -2.5, -5	
10	Temperature-Rise	-	
10.1	Maximum Top Oil Temperature-Rise, °C	45	
10.2	Maximum Average Winding Temperature-Rise, °C	50	
10.3	Maximum Hot Spot Temperature, °C	98	
10.4	Temperature-Rise Due to Short-Circuit Current Above hottest Spot After Full-Load, °C	200	
11	Dimensions and Mass	-	
11.1	Overall Dimension of Completely Assembled Transformer: - Width, mm - Depth, mm - Height, mm		
11.2	Mass: - Mass of Core of Winding, kg - Mass of Tank (Empty), kg - Mass of Oil, kg - Total Mass of Completely Assembled Transformer, kg - Shipping Mass, kg		

SPECIFICATION FOR DISTRIBUTION TRANSFORMERS W/ ALUMINUM WINDINGS INCLUDING DUAL PRIMARY W/ DUAL SECONDARY

Issue Date: 16/7/2019 Page: 22 of 29

51-SDMS-04 REV.02

12	Tank	-	
12.1	Tank Construction		
12.2	Top Oil Temperature for Internal Pressure of 30kN/m ² , °C		
12.3	Steady Load at 40°C Ambient Temperature at Condition Given in Item 12.2, kVA		
12.4	Steady Load at 40°C Ambient Temperature Considering the Effect of Solar Radiation, kVA		
12.5	Maximum Withstand Pressure of the Tank for 24Hours without Leaking, kN/mm ²		
12.6	Tank Steel Thickness, mm		
12.7	Radiator Steel Thickness, mm		
13	Primary Bushings (HV Side)	-	
13.1	Manufacturer		
13.2	Origin		
13.3	Material / Color		
13.4	Rated Current, A		
13.5	Rated Thermal Current: - 1 Second, kA - 3 Seconds, kA		
13.6	Impulse Withstand Voltage, kV _{peak}		
13.7	Impulse Flashover Voltage, kV _{peak}		
13.8	Power Frequency Withstand Voltage: - Dry, kV _{rms} - Wet, kV _{rms}		
13.9	Power Frequency Flashover Voltage: - Dry, kV _{rms} - Wet, kV _{rms}		
13.10	Puncture Voltage, kV		
13.11	Maximum Withstand Salinity, kg/m ³		
13.12	Maximum Withstand Voltage at 224kg/m ³ salinity at 20°C, kV		
13.13	Total Creepage Distance, mm		
14	Secondary Bushings (LV Side)	-	
14.1	Manufacturer		
14.2	Origin		

**SPECIFICATION FOR DISTRIBUTION
TRANSFORMERS W/ ALUMINUM
WINDINGS INCLUDING
DUAL PRIMARY W/ DUAL SECONDARY**

Issue Date: 16/7/2019 **Page:** 23 of 29

51-SDMS-04 REV.02

14.3	Material / Color		
14.4	Rated Current, A		
14.5	Rated Thermal Current: - 1 Second, kA - 3 Seconds, kA		
14.6	Impulse Withstand Voltage, kV _{peak}		
14.7	Power Frequency Withstand Voltage: - Dry, kV _{rms} - Wet, kV _{rms}		
14.8	Total Creepage Distance, mm		
15	Supplementary Fittings	-	
15.1	Is the transformer fitted with all the accessories mentioned in this specification?	Yes	
15.2	Type and Make of Each Accessories: - Temperature Indicator - Pressure Relief Vent - Oil Level Indicator		
16	List of Deviations, if any	-	
17	Others	-	
	Product is Type Tested	Yes	
	SEC Approved Laboratory	**	

**SPECIFICATION FOR DISTRIBUTION
TRANSFORMERS W/ ALUMINUM
WINDINGS INLCUDING
DUAL PRIMARY W/ DUAL SECONDARY**

Issue Date: 16/7/2019 **Page:** 24 of 29

51-SDMS-04 REV.02

Date Tested	**	
Manufacturer	**	
Model/Type	**	
Country of Origin	**	
Submittals Required with Tender/Inquiry Included or Not?	**	

**SPECIFICATION FOR DISTRIBUTION
TRANSFORMERS W/ ALUMINUM
WINDINGS INLCUDING
DUAL PRIMARY W/ DUAL SECONDARY**

Issue Date: 16/7/2019 **Page:** 25 of 29

51-SDMS-04 REV.02

Distribution Transformers with Aluminum Windings

SEC Inquiry No:

Item No:

Additional Technical Information or Features Specified by SEC

Additional Supplementary Data or Features Proposed by Bidder/Vendor/Supplier.

Other Particulars to be filled-up by the Bidder/Vendor/Supplier.

List of Deviations and Clauses to which exception is taken by the Bidder/Vendor/Supplier. (Use separate sheet, if necessary).

Description	Manufacturer of Material/Equipment	Vendor/Supplier
Name of Company		
Location and Office Address		
Name and Signature of Authorized Representative with Date		
Official Seal / Stamp		

SPECIFICATION FOR DISTRIBUTION TRANSFORMERS W/ ALUMINUM WINDINGS INCLUDING DUAL PRIMARY W/ DUAL SECONDARY

Issue Date: 16/7/2019 Page: 26 of 29

51-SDMS-04 REV.02

12 Drawings

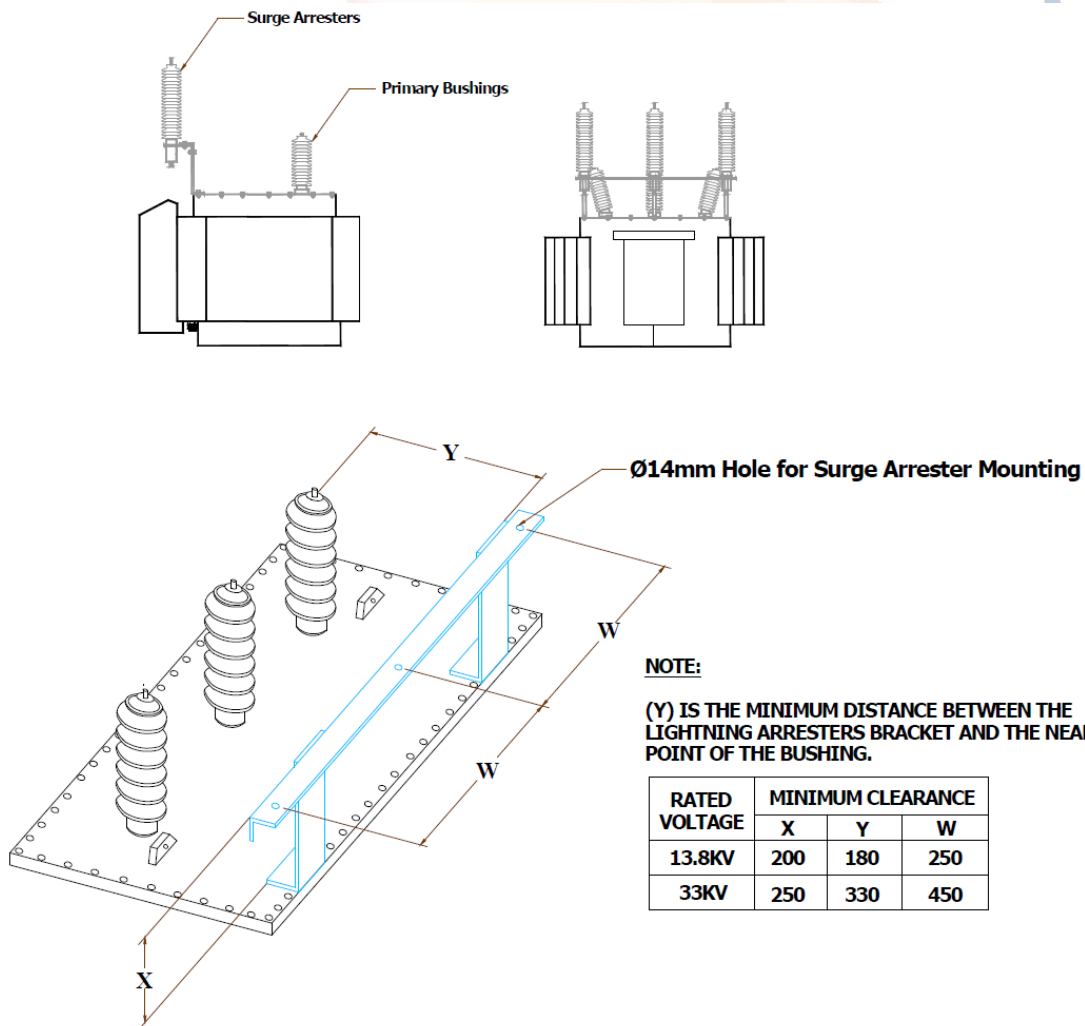

Figure 1: Surge arresters mounting bracket for pole-mounted transformers

**SPECIFICATION FOR DISTRIBUTION
TRANSFORMERS W/ ALUMINUM
WINDINGS INCLUDING
DUAL PRIMARY W/ DUAL SECONDARY**

Issue Date: 16/7/2019 **Page:** 27 of 29

51-SDMS-04 REV.02

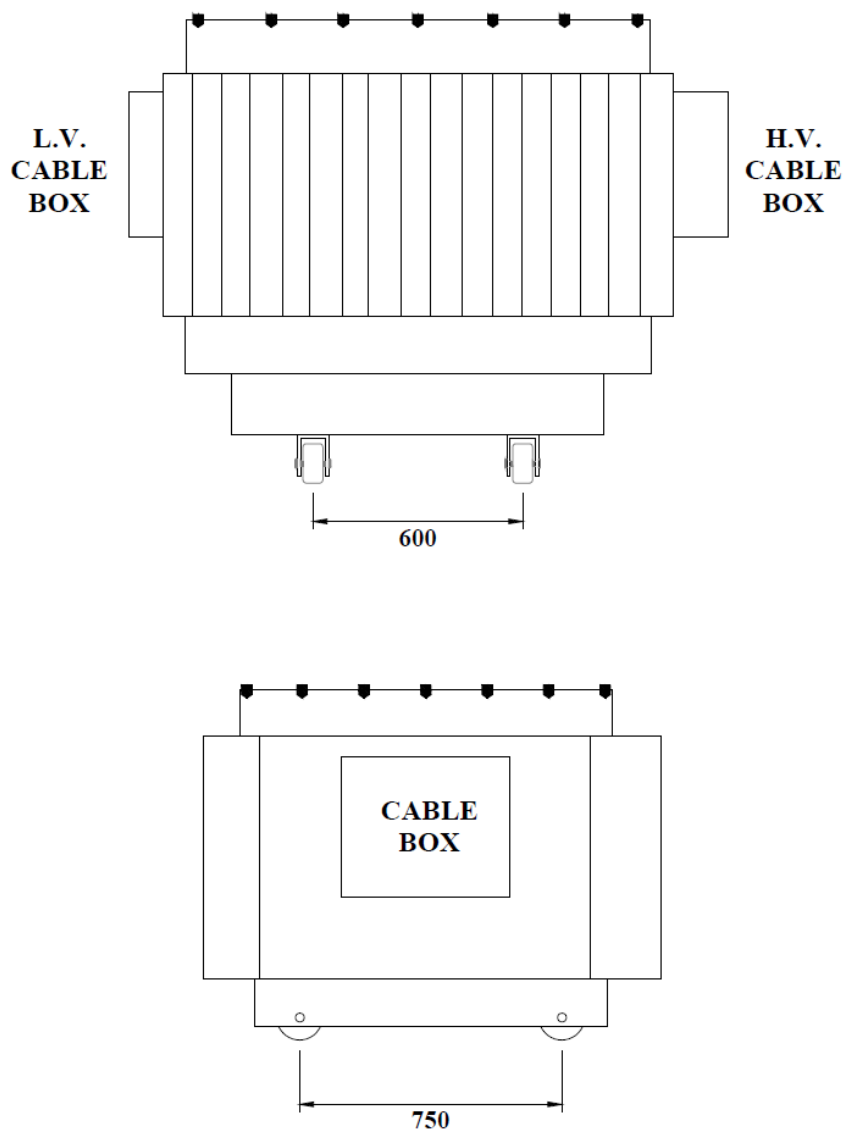

Figure 2: Rollers spacing for pad-mounted transformers

**SPECIFICATION FOR DISTRIBUTION
TRANSFORMERS W/ ALUMINUM
WINDINGS INLCUDING
DUAL PRIMARY W/ DUAL SECONDARY**

Issue Date: 16/7/2019 **Page:** 28 of 29

51-SDMS-04 REV.02

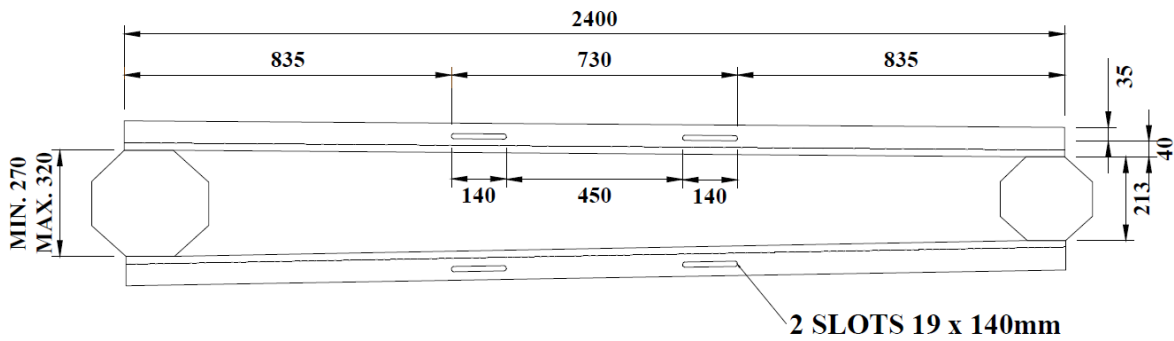

Figure 3: Mounting base for 200kVA and 300kVA pole-mounted transformers

SPECIFICATION FOR DISTRIBUTION TRANSFORMERS W/ ALUMINUM WINDINGS INCLUDING DUAL PRIMARY W/ DUAL SECONDARY

Issue Date: 16/7/2019 Page: 29 of 29

51-SDMS-04 REV.02

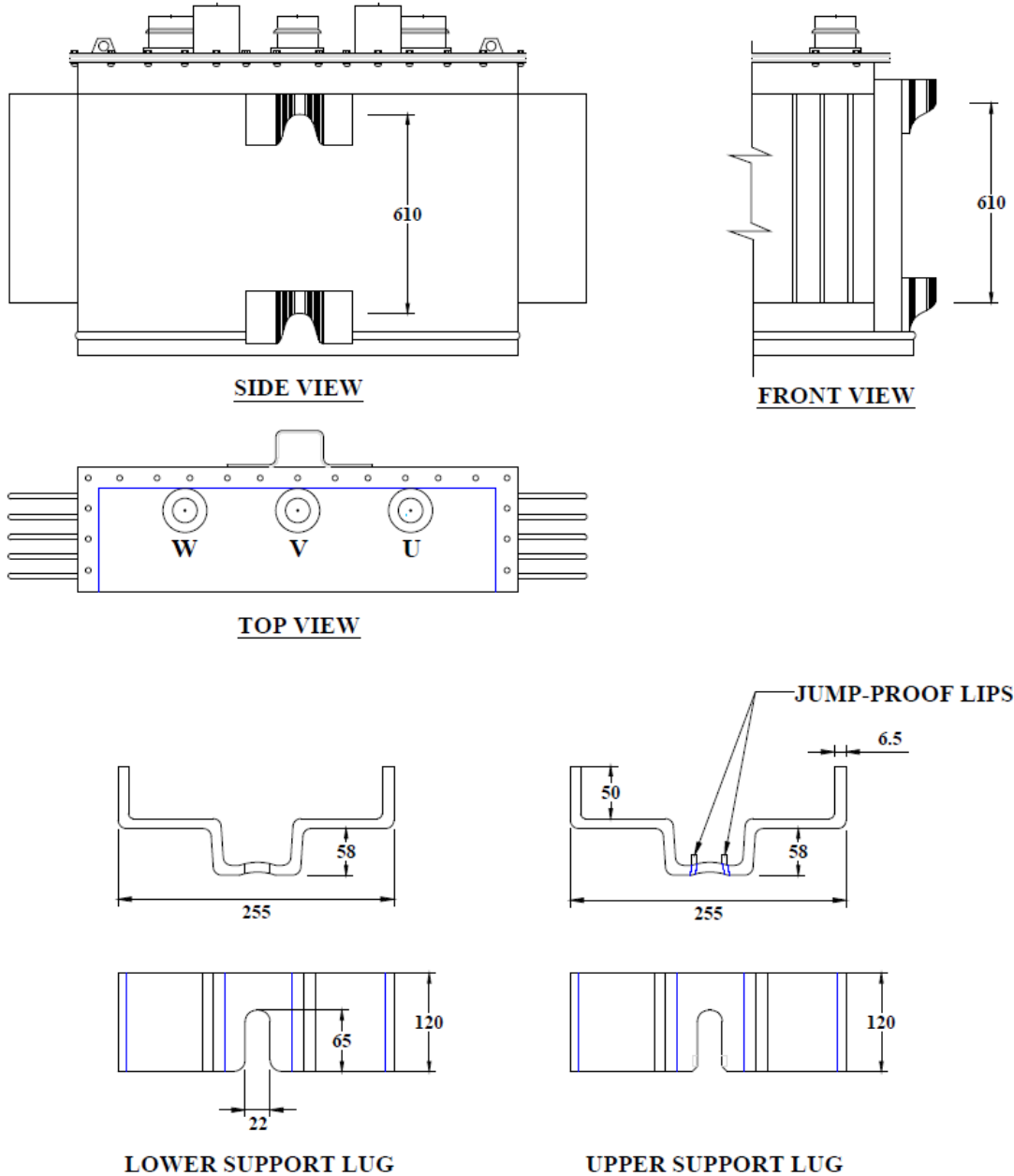

Figure 4: Support bracket for 100kVA pole-mounted transformer